

DESIGN NOTES

Multiple Output Isolated Power Supply Achieves High Efficiency with Secondary Side Synchronous Post Regulator – Design Note 299

Charlie Zhao and Wei Chen

Introduction

The newly released LT[®]3710, a secondary side synchronous post regulator controller, provides tight regulation for all outputs of multiple output isolated power supplies. Solutions that use the LT3710 are efficient, use minimal space and provide fast transient response.

The LT3710 is a voltage mode controller with leading edge modulation, programmable current limit and dual MOSFET drivers. It generates a tightly regulated second output directly from the transformer secondary winding, thus minimizing the size of the output inductor and capacitor of the main output stage. The use of synchronous MOSFETs significantly improves efficiency, making it suitable for low output voltage applications.

Design Example

Figures 1a and 1b show a dual output high efficiency isolated DC/DC power supply with 36V to 72V input range and two outputs of 3.3V/10A and 2.5V/10A. The basic power stage topology is a 2-switch forward converter with

synchronous rectification. The primary side controller uses the LT3781; a current mode 2-switch forward controller with built-in MOSFET drivers. On the secondary side a synchronous rectifier controller, the LTC1698, provides the voltage feedback for the main 3.3V output as well as the gate drive for the synchronous MOSFETs. The LT3710 circuit precisely regulates the 2.5V output. Total load and line regulation for the 2.5V output is better than 0.2%. From a 48V input, the overall efficiency is about 87% with full load on both outputs.

Conclusion

The LT3710 is a high efficiency secondary side synchronous post regulator controller that is designed to generate a tightly regulated secondary output for multiple output isolated power supplies. It can be used with any buck derived single-ended or dual-ended isolated topologies, such as forward, push-pull, half-bridge and full-bridge converters.

LT, LTC and LT are registered trademarks of Linear Technology Corporation.

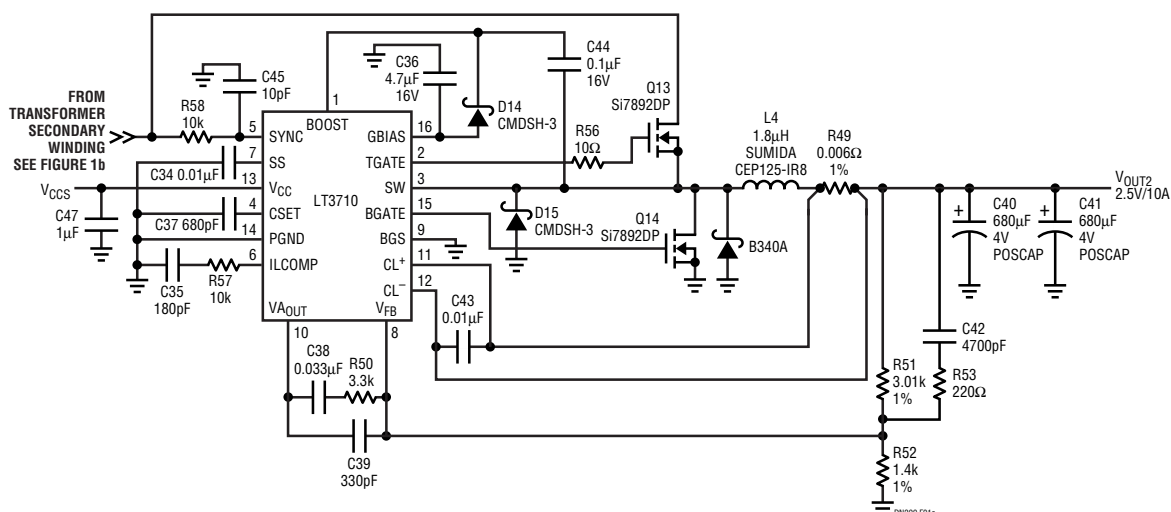

Figure 1a. 36V to 72V DC to 3.3V/10A and 2.5V/10A Dual Output Isolated Power Supply (Part 1 of 2: Post Regulator Circuit)

